



U.S. Department of Energy  
**Energy Efficiency  
and Renewable Energy**

Bringing you a prosperous future where energy  
is clean, abundant, reliable, and affordable

 Building Energy Codes Program

# 2009 IECC

## Commercial Envelope Requirements

U.S. Department of Energy  
Building Energy Codes Program

# Major Changes to the Envelope Requirements

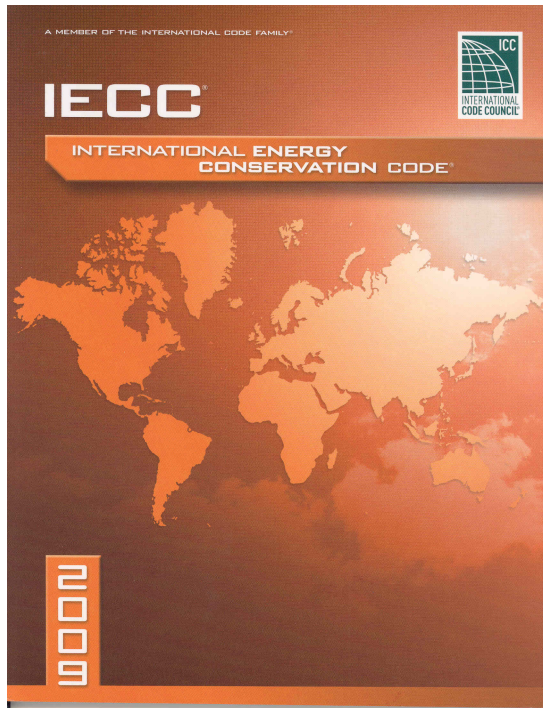

- Commercial Provisions Contained in Chapter 5
  - IECC
  - ASHRAE 90.1-2007
- Tables 502.2(1) and Table 502.2(2) Building Envelope Requirements – Opaque Assemblies

# Introduction to the Energy Code Compliance Process

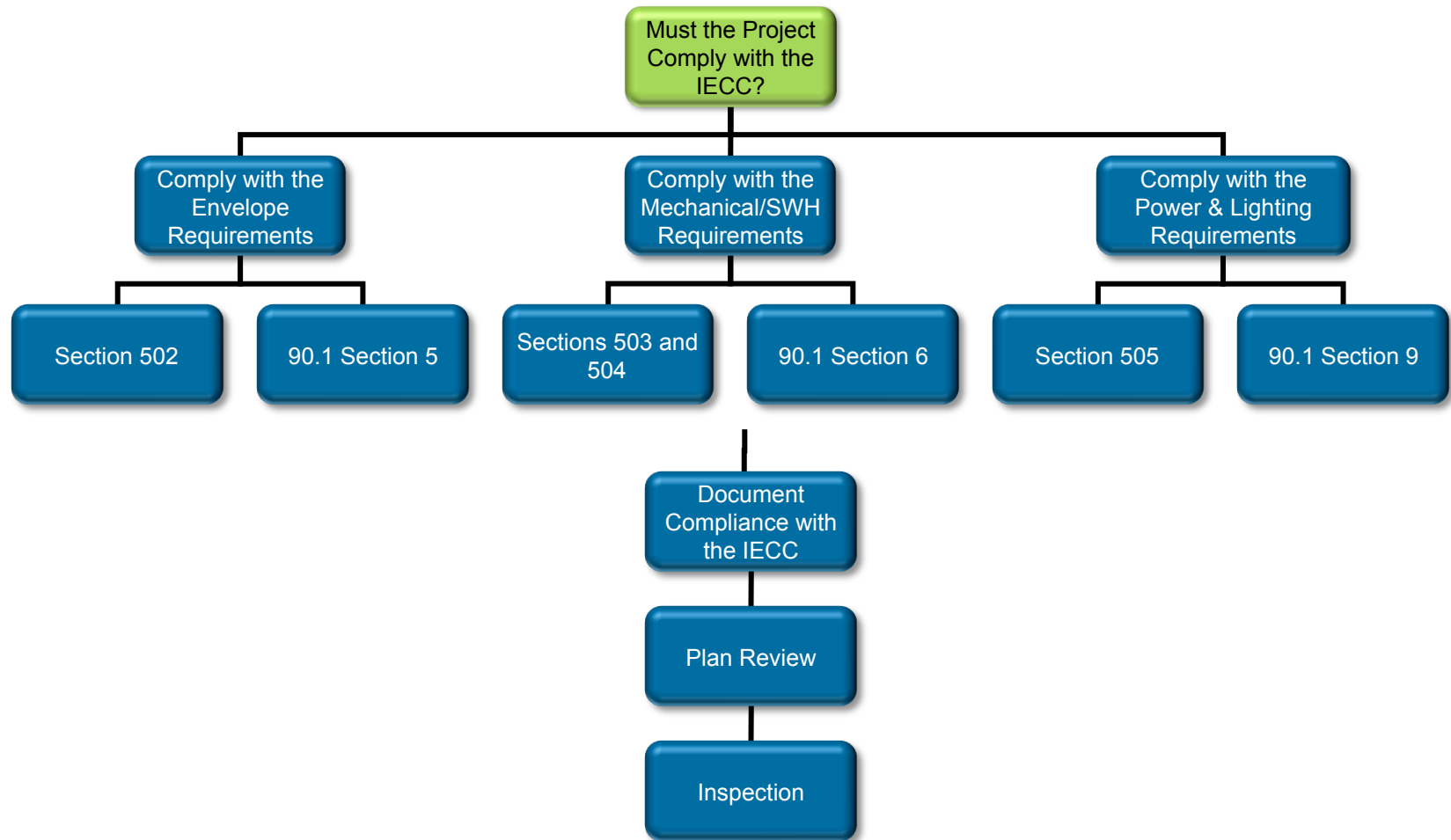

# Does My Project Need to Comply with the Commercial Provisions in the IECC?



All Buildings Other Than:

- One- and two-family residential
- R-2, R-3, R-4 three stories or less in height



# Introduction to the Commercial Energy Code Compliance Process

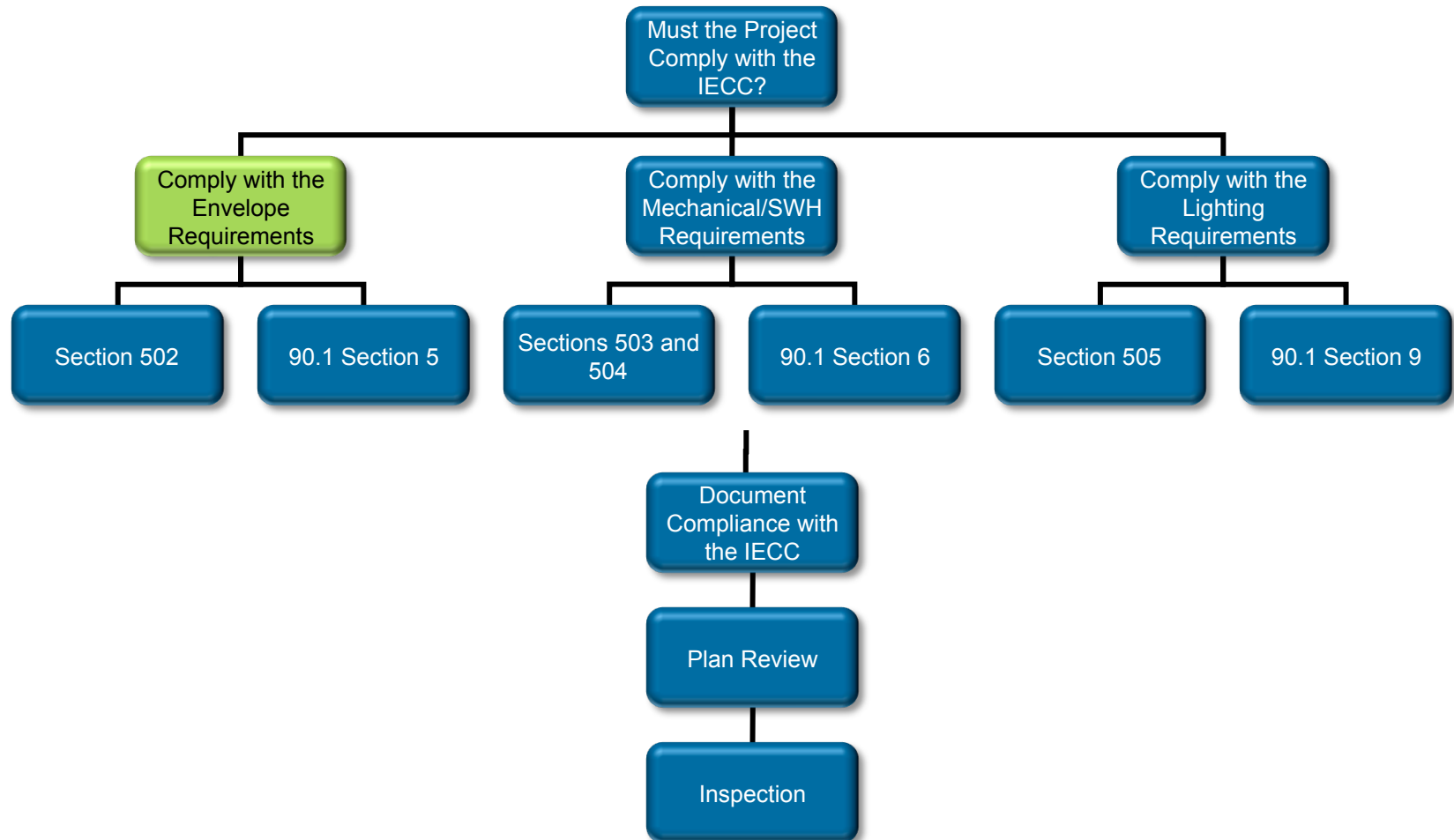

# What is the Building Thermal Envelope?

---

- Roof/Ceiling Assembly
- Wall Assembly
- Vertical Fenestration and Skylights
- Floor Assembly
- Slab Edge
- Below Grade Wall Assembly

# What are My Options for Complying with the IECC?



- Chapter 5 of the IECC General Prescriptive Approach
  - Use for  $\leq 40\%$  of gross wall area in vertical fenestration
  - Use for  $\leq 3\%$  of gross roof area in skylights
- Section 506 Total Building Performance Approach
- ASHRAE/IESNA Standard 90.1-2007
  - Section 501.2 “Application” requires 90.1 to be used in its entirety (Envelope, Lighting, Mechanical) if used as an alternate compliance path



# Climate Zones—2009 IECC

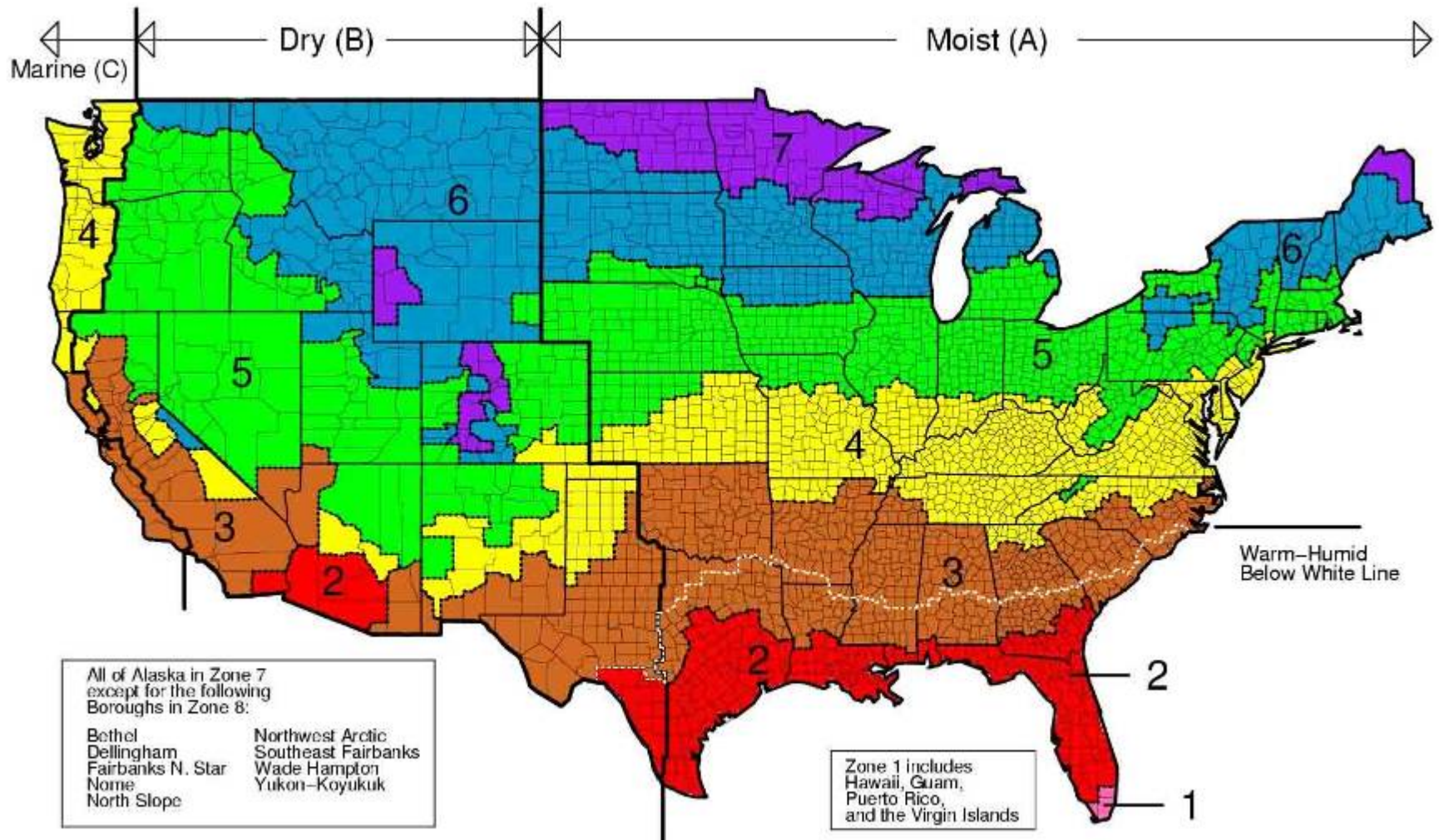

Determining Your Climate Zone is the First Step in the Process



# Changes to Tables 502.1.2 and 502.2(1)

---

- Table now separated by occupancy type
  - Group R occupancies use “Group R” column
  - Non-Group R occupancies use “All other” column

# Compliance with Chapter 5 Prescriptive Approach

TABLE 502.2(1)  
BUILDING ENVELOPE REQUIREMENTS - OPAQUE ASSEMBLIES

CLIMATE ZONE	1		2		3		4 EXCEPT MARINE		5 AND MARINE 4		6		7		8		
	All other	Group R	All other	Group R	All other	Group R	All other	Group R	All other	Group R	All other	Group R	All other	Group R	All other	Group R	
<b>Roofs</b>																	
Insulation entirely above deck	R-15ci	R-20ci	R-20ci	R-20ci	R-20ci	R-20ci	R-20ci	R-20ci	R-20ci	R-20ci	R-20ci	R-20ci	R-20ci	R-25ci	R-25ci	R-25ci	R-25ci
Metal buildings (with R-5 thermal blocks <sup>a, b</sup> )	R-19	R-19	R-13 + R-13	R-13 + R-13	R-13 + R-13	R-19	R-13 + R-13	R-19	R-13 + R-13	R-19	R-13 + R-19	R-19	R-13 + R-19	R-19 + R-10	R-11 + R-19	R-19 + R-10	
Attic and other	R-30	R-38	R-38	R-38	R-38	R-38	R-38	R-38	R-38	R-38	R-38	R-38	R-38	R-38	R-49	R-49	
<b>Walls, Above Grade</b>																	
Mass	NR	R-5.7ci	R-5.7ci	R-7.6ci	R-7.6ci	R-9.5ci	R-9.5ci <sup>c</sup>	R-11.4ci	R-11.4ci	R-13.3ci	R-13.3ci	R-15.2ci	R-15.2ci	R-15.2ci	R-25ci	R-25ci	
Metal building <sup>b</sup>	R-16	R-16	R-16	R-16	R-19	R-19	R-19	R-19	R-13 + R-5.6ci	R-13 + R-5.6ci	R-13 + R-5.6ci	R-13 + R-5.6ci	R-19 + R-5.6ci	R-19 + R-5.6ci	R-19 + R-5.6ci	R-19 + R-5.6ci	
Metal framed	R-13	R-13	R-13	R-13 + 7.5ci	R-13 + R-3.8ci	R-13 + R-7.5ci	R-13 + 7.5	R-13 + R-7.5ci	R-13 + R-7.5ci	R-13 + R-7.5ci	R-13 + R-7.5ci	R-13 + R-7.5ci	R-13 + R-7.5ci	R-13 + R-7.5ci	R-13 + R-15.6ci	R-13 + R-18.8ci	
Wood framed and other	R-13	R-13	R-13	R-13	R-13	R-13	R-13	R-13 + R-3.8ci	R-13 + R-3.8ci	R-13 + 3.8	R-13 + 7.5	R-13 + R-7.5	R-13 + R-7.5ci	R-13 + 7.5ci	R-13 + R-15.6ci	R-13 + 15.6ci	
<b>Walls, Below Grade</b>																	
Below grade wall <sup>d</sup>	NR	NR	NR	NR	NR	NR	NR	R-7.5ci	R-7.5ci	R-7.5ci	NR R-7.5ci	R-7.5ci	R-7.5ci	R-10ci	R-7.5ci	R-12.5ci	
<b>Floors</b>																	
Mass	NR	NR	R-6.3ci	R-8.3ci	R-6.3ci	R-8.3ci	R-10ci	R-10.4ci	R-10ci	R-12.5ci	R-12.5ci	R-14.6ci	R-15ci	R-16.7ci	R-15ci	R-16.7ci	
Joist/framing Steel/(wood)	NR	NR	R-19	R-30	R-19	R-30	R-30	R-30	R-30	R-30	R-30	R-30 <sup>e</sup>	R-30	R-30 <sup>e</sup>	R-30 <sup>e</sup>	R-30 <sup>e</sup>	
<b>Slab-on-Grade Floors</b>																	
Unheated slabs	NR	NR	NR	NR	NR	NR	NR	R-10 for 24 in. below	NR	R-10 for 24 in. below	R-10 for 24 in. below	R-15 for 24 in. below	R-15 for 24 in. below	R-15 for 24 in. below	R-15 for 24 in. below	R-20 for 24 in. below	
Heated slabs	R-7.5 for 12 in. below	R-7.5 for 12 in. below	R-7.5 for 12 in. below	R-7.5 for 12 in. below	R-10 for 24 in. below	R-10 for 24 in. below	R-15 for 24 in. below	R-15 for 24 in. below	R-15 for 24 in. below	R-15 for 24 in. below	R-15 for 24 in. below	R-20 for 48 in. below	R-20 for 24 in. below	R-20 for 48 in. below	R-20 for 48 in. below	R-20 for 48 in. below	
Opaque doors																	
Swinging	U-0.70	U-0.70	U-0.70	U-0.70	U-0.70	U-0.70	U-0.70	U-0.70	U-0.70	U-0.70	U-0.70	U-0.50	U-0.50	U-0.50	U-0.50	U-0.50	
Roll-up or sliding	U-1.45	U-1.45	U-1.45	U-1.45	U-1.45	U-1.45	U-0.50	U-0.50	U-0.50	U-0.50	U-0.50	U-0.50	U-0.50	U-0.50	U-0.50	U-0.50	

For SI: 1 inch = 25.4 mm.

ci = Continuous insulation. NR = No requirement.

a. When using R-value compliance method, a thermal spacer block is required, otherwise use the U-factor compliance method. [see Tables 502.1.2 and 502.2(2)].

b. Assembly descriptions can be found in Table 502.2(2).

c. R-5.7 ci is allowed to be substituted with concrete block walls complying with ASTM C 90, ungrouted or partially grouted at 32 inches or less on center vertically and 48 inches or less on center horizontally, with ungrouted cores filled with material having a maximum thermal conductivity of 0.44 Btu-in./h-<sup>2</sup> F.

d. When heated slabs are placed below grade, below-grade walls must meet the exterior insulation requirements for perimeter insulation according to the heated slab-on-grade construction.

e. Steel floor joist systems shall to be R-38.

# Compliance with Chapter 5 Prescriptive Approach

TABLE 502.2(2)  
BUILDING ENVELOPE REQUIREMENTS—OPAQUE ASSEMBLIES

ROOFS	DESCRIPTION	REFERENCE
R-19	<p>Standing seam roof with single fiberglass insulation layer.</p> <p>This construction is R-19 faced fiberglass insulation batts draped perpendicular over the purlins. A minimum R-3.5 thermal spacer block is placed above the purlin/batt, and the roof deck is secured to the purlins.</p>	ASHRAE/IESNA 90.1 Table A2.3 including Addendum "G"
R-13 + R-13 R-13 + R-19	<p>Standing seam roof with two fiberglass insulation layers.</p> <p>The first <i>R</i>-value is for faced fiberglass insulation batts draped over purlins. The second <i>R</i>-value is for unfaced fiberglass insulation batts installed parallel to the purlins. A minimum R-3.5 thermal spacer block is placed above the purlin/batt, and the roof deck is secured to the purlins.</p>	ASHRAE/IESNA 90.1 Table A2.3 including Addendum "G"
R-11 + R-19 FC	<p>Filled cavity fiberglass insulation.</p> <p>A continuous vapor barrier is installed below the purlins and uninterrupted by framing members. Both layers of uncompressed, unfaced fiberglass insulation rest on top of the vapor barrier and are installed parallel, between the purlins. A minimum R-3.5 thermal spacer block is placed above the purlin/batt, and the roof deck is secured to the purlins.</p>	ASHRAE/IESNA 90.1 Table A2.3 including Addendum "G"
<b>WALLS</b>		
R-16, R-19	<p>Single fiberglass insulation layer.</p> <p>The construction is faced fiberglass insulation batts installed vertically and compressed between the metal wall panels and the steel framing.</p>	ASHRAE/IESNA 90.1 Table A3.2 including Addendum "G"
R-13 + R-5.6 ci R-19 + R-5.6 ci	<p>The first <i>R</i>-value is for faced fiberglass insulation batts installed perpendicular and compressed between the metal wall panels and the steel framing. The second rated <i>R</i>-value is for continuous rigid insulation installed between the metal wall panel and steel framing, or on the interior of the steel framing.</p>	ASHRAE/IESNA 90.1 Table A3.2 including Addendum "G"

## Roof R-Value (502.2.1) / U-Factor (502.1.2)



Roof R-values and U-factor requirements are based on assembly type / insulation placement

- Insulation entirely above deck
- Metal buildings
- Attic and other

# Roof R-Value – Insulation Completely Above Deck

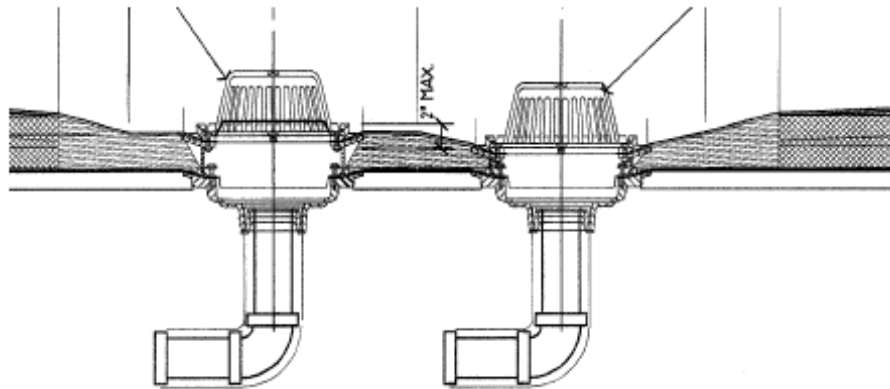

- Insulation considered continuous (*CI*)
- Insulation thickness can vary  $\leq 1$ " and area weighted U-factor meets the requirements of Table 502.2(1)



## Roof R-Value – Insulation Placed on Suspended Ceiling with Removable Ceiling Tiles

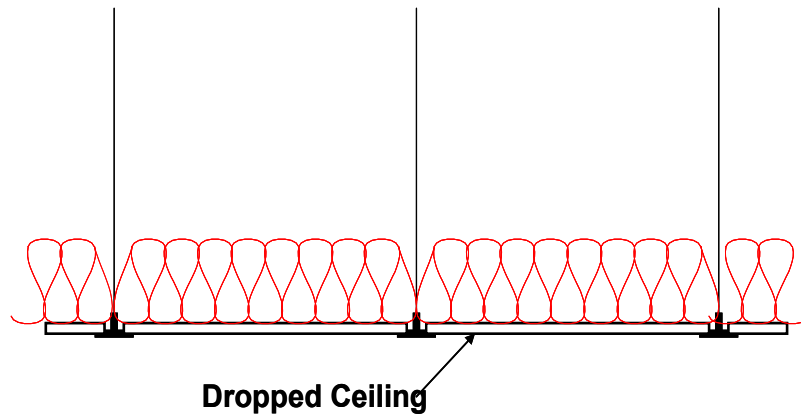

- Will not count for code compliance
- Will not comply with Section 502.4.3 – “Sealing of the building envelope”

# Roof R-Value – Metal Buildings

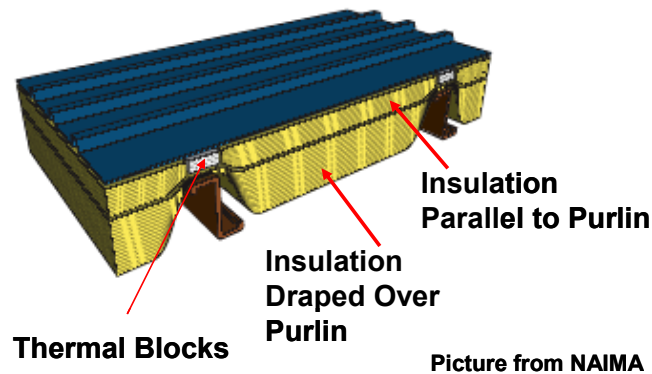

- R-5 thermal blocks required on all metal buildings or must use U-factor Compliance Method
- Climate Zones 2-8 require two layers of insulation
  - CZ 2-5 and marine R: R-13+R-13
  - CZ 6-7: R-13+R-19
  - CZ 8: R-11+R-19
- Example (R-13+R-19):
  - R-13 draped perpendicularly to the purlins
  - R-19 running parallel to the purlins supported by the R-13

# Roof R-Value – Ceilings with Attic Spaces

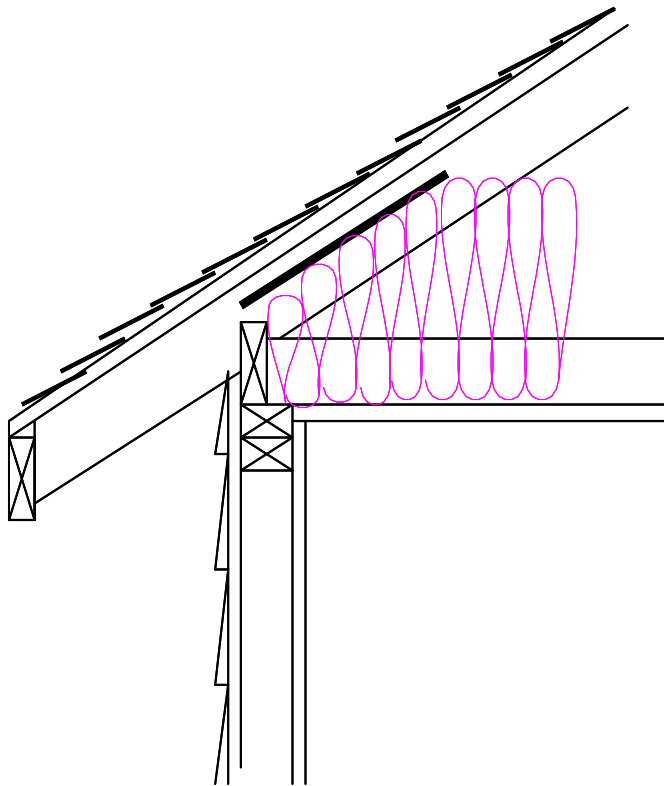

- Install insulation between framing
- R-38 in most Climate Zones
- R-30 in Climate Zones 1 and R-49 in Climate Zone 8

# Wall R-Value – Mass Walls



- Walls weighing at least 35 lbs/ft<sup>2</sup> of wall surface area, or
- 25 lbs/ft<sup>2</sup> of wall surface area if material weight is  $\leq 120 \text{ lb/ft}^3$

# Mass Walls – Concrete Masonry Units

- Climate Zone 4 except marine – Can use integral insulation instead of R-5.7 ci
  - Concrete block walls must comply with ASTM C 90, and
  - UngROUTED or partially grouted @ 32 inch. o.c. or less vertically or 48 inch. o.c. or less horizontally, and
  - UngROUTED cells must be filled with insulation material  $\leq$  of 0.44 Btu-in./h-ft<sup>2</sup> F
- Climate Zone 1
  - No insulation required for mass walls



## Wall R-Value – Wood, Metal Frame, and Other

---

- Cavity insulation or cavity plus continuous (ci)
- Continuous insulation not broken up by framing members e.g. rigid board insulation

# Metal Building Walls [Table 502.2(2)]



Picture from NAIMA

Climate Zone	R-Value
1-2	R-16
3-4 except Marine	R-19
Marine 4 – 6	R-13+R-5.6ci
7-8	R-19+R-5.6ci

## Below Grade Walls (502.2.4)

- What is a below grade wall?
  - Basement or first-story walls  $\geq 85\%$  below grade
- Insulation must extend down 10 ft from the outside finished grade level or to the level of the floor, whichever is less
- Heated slabs installed below grade [Footnote d to Table 502.2(1)]
  - Below grade walls must meet exterior insulation requirements for perimeter insulation according to heated slab-on-grade construction

# Floors Over Outdoor Air or Unconditioned Space (502.2.5)



- Joist/Framing (Steel/Wood)
  - Insulation installed between framing
- Mass Floors
  - Materials weighing 35 lbs/ft<sup>2</sup>, or
  - 25 lbs/ft<sup>2</sup> if material weight is  $\leq$  120 lbs/ft<sup>3</sup>
  - Insulation installed continuously
- Steel Floor Joist Systems [Footnote e to Table 502.2 (1)]
  - R-38 in Climate Zones 6-8

## Slab-on-Grade Floors (502.2.6)

---

- Unheated slab – insulation required in Climate Zones 4-8
- Heated slabs – insulation required in all Climate Zones



# Opaque Doors (502.2.7)



- Doors having  $< 50\%$  glass area
- Swinging doors
  - Meet U-factor requirement
- Roll-up or sliding doors
  - Climate zones 1 - 3: U-1.45
  - Climate zones 4 including Marine - 8: U-0.50

# Compliance with Chapter 5 Prescriptive Approach

TABLE 502.3  
BUILDING ENVELOPE REQUIREMENTS: FENESTRATION

CLIMATE ZONE	1	2	3	4 EXCEPT MARINE	5 AND MARINE 4	6	7	8
<b>Vertical fenestration (40% maximum of above-grade wall)</b>								
<b>U-factor</b>								
<b>Framing materials other than metal with or without metal reinforcement or cladding</b>								
U-factor	1.20	0.75	0.65	0.40	0.35	0.35	0.35	0.35
<b>Metal framing with or without thermal break</b>								
Curtain wall/storefront U-factor	1.0	0.70	0.60	0.50	0.45	0.45	0.40	0.40
Entrance door U-factor	1.20	1.10	0.90	0.85	0.80	0.80	0.80	0.80
All other U-factor <sup>a</sup>	1.20	0.75	0.65	0.55	0.55	0.55	0.45	0.45
<b>SHGC-all frame types</b>								
SHGC: PF < 0.25	0.25	0.25	0.25	0.40	0.40	0.40	0.45	0.45
SHGC: 0.25 ≤ PF < 0.5	0.33	0.33	0.33	NR	NR	NR	NR	NR
SHGC: PF ≥ 0.5	0.40	0.40	0.40	NR	NR	NR	NR	NR
<b>Skylights (3% maximum)</b>								
U-factor	0.75	0.75	0.65	0.60	0.60	0.60	0.60	0.60
SHGC	0.35	0.35	0.35	0.40	0.40	0.40	NR	NR

NR = No requirement.

PF = Projection factor (see Section 502.3.2).

a. All others includes operable windows, fixed windows and nonentrance doors.

# Vertical Fenestration Requirement (502.3.1) - Prescriptive



Percentage of Vertical Fenestration Area to Gross Wall Area

- Allowed up to 40% maximum of above grade wall

# Vertical Fenestration Requirement (502.3.1)



- Based on above-grade wall area (gross)
  - Includes walls between conditioned space and unconditioned space or the great outdoors
    - Includes walls that are > 15% above grade
- Total fenestration area (includes frame and glazing)
  - Does not include opaque door area

# Fenestration U-Factor (502.3.2)

Framing Materials Other Than Metal w/ or w/o metal reinforcement or cladding

- Includes vinyl and wood frame products or other non-metal frames
- Typically manufactured fenestration products





# Fenestration U-Factor – Curtain Wall



- By definition: Fenestration products used to create an external nonload-bearing wall that is designed to separate the exterior and interior environments

# Fenestration U-Factor – Storefront



- By definition: A nonresidential system of doors and windows mullioned as a composite fenestration structure that has been designed to resist heavy use.

Storefront systems include, but are not limited to, exterior fenestration systems that span from the floor level or above to the ceiling of the same story on commercial buildings.

# Fenestration U-Factor – Entrance Door



- By definition: Fenestration products used for ingress, egress and access in nonresidential buildings, including but not limited to, exterior entrances that utilize latching hardware and automatic closers and contain over 50% glass specifically designed to withstand heavy use and possibly abuse



# Fenestration U-Factor – All Other

---

- Includes operable windows, fixed windows and non-entrance doors

# Fenestration U-Factor (303.1.3)

		<b>World's Best Window Co.</b> Millennium 2000+ Vinyl-Clad Wood Frame Double Glazing • Argon Fill • Low E Product Type: Vertical Slider	
<b>ENERGY PERFORMANCE RATINGS</b>			
U-Factor (U.S./I-P)		Solar Heat Gain Coefficient	
<b>0.35</b>		<b>0.32</b>	
<b>ADDITIONAL PERFORMANCE RATINGS</b>			
Visible Transmittance		Air Leakage (U.S./I-P)	
<b>0.51</b>		<b>0.2</b>	
Condensation Resistance		_____	
<b>51</b>			
<small>Manufacturer stipulates that these ratings conform to applicable NFRC procedures for determining whole product performance. NFRC ratings are determined for a fixed set of environmental conditions and a specific product size. Consult manufacturer's literature for other product performance information.  <a href="http://www.nfrc.org">www.nfrc.org</a></small>			

## How Do You Meet the Requirement?

- Fenestration product rating in accordance to NFRC 100
- Labeled and certified by the manufacturer
- Non-NFRC 100 rated fenestration
- Default Glazed Fenestration U-factor Table 102.1.3(1)

# Default U-Factors from Tables 303.1.3(1) and (2)

**TABLE 303.1.3(1)  
DEFAULT GLAZED FENESTRATION U-FACTOR**

FRAME TYPE	SINGLE PANE	DOUBLE PANE	SKYLIGHT	
			Single	Double
Metal	1.20	0.80	2.00	1.30
Metal with Thermal Break	1.10	0.65	1.90	1.10
Nonmetal or Metal Clad	0.95	0.55	1.75	1.05
Glazed Block	0.60			

**TABLE 303.1.3(2)  
DEFAULT DOOR U-FACTORS**

DOOR TYPE	U-FACTOR
Uninsulated Metal	1.20
Insulated Metal	0.60
Wood	0.50
Insulated, nonmetal edge, max 45% glazing, any glazing double pane	0.35

# Glazed Fenestration SHGC (502.3.2)



What is Solar Heat Gain Coefficient?

“The ratio of the solar heat gain entering the space through the fenestration assembly to the incident solar radiation.”

# Fenestration SHGC Requirements – Table 303.1.3(3)

TABLE 303.1.3(3)  
DEFAULT GLAZED FENESTRATION SHGC

SINGLE GLAZED		DOUBLE GLAZED		GLAZED BLOCK
Clear	Tinted	Clear	Tinted	
0.8	0.7	0.7	0.6	0.6

## Two Options for Meeting the SHGC Requirements

- Fenestration product rated and labeled to NFRC 200, or
- Select default from Table 303.1.3(3)

# Fenestration SHGC Requirements

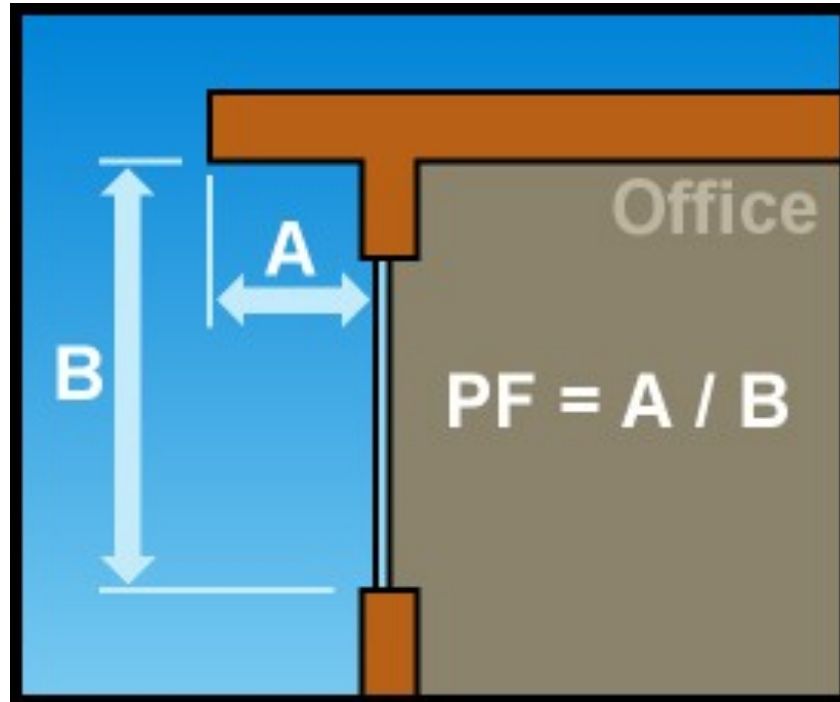

## The Effect of Overhangs on Fenestration SHGC

- Overhangs allow a higher SHGC product to be installed
- Projection factor must be calculated

# Skylight U-Factor / SHGC

- Limited to  $\leq 3\%$  of Roof Area
- U-factor and SHGC Based
- NFRC 100 Rating for U-factor or Default Table
- No SHGC requirements in Climate Zones 7-8



# NFRC 100 Rating for U-factor or Default Table

**TABLE 303.1.3(1)  
DEFAULT GLAZED FENESTRATION U-FACTOR**

FRAME TYPE	SINGLE PANE	DOUBLE PANE	SKYLIGHT	
			Single	Double
Metal	1.20	0.80	2.00	1.30
Metal with Thermal Break	1.10	0.65	1.90	1.10
Nonmetal or Metal Clad	0.95	0.55	1.75	1.05
Glazed Block	0.60			



# Mandatory Requirements – Sealing of the Building Envelope (502.4.3)

- All penetrations, openings, joints and seams in the building envelope must be sealed. Materials that can be used include:
  - Caulking
  - Gasketing
  - Tapes
  - Moisture vapor-permeable wrapping material
- Sealing materials spanning joints between dissimilar materials must allow for expansion and contraction



# Hot Gas Bypass (502.4.4)

- Cooling systems can't use unless system designed with
  - multiple steps of unloading OR
  - Continuous capacity modulation
- Capacity limited per Table 502.4.4
- Exception
  - Unitary packaged systems with cooling capacities < 90,000 Btu/h

<b>Rated Capacity</b>	<b>Maximum Hot Gas Bypass Capacity (% of total capacity)</b>
≤ 240,000 Btu/h	50%
> 240,000 Btu/h	25%

# Mandatory Requirements – Outdoor Air Intakes and Exhaust Openings (502.4.5)



- Buildings  $\geq 3$  stories in height above grade
  - Class 1 motorized leakage-rated damper
    - Maximum leakage rate  $\leq 4\text{cfm /ft}^2 @ 1.0 \text{ inch w.g.}$
- Buildings  $< 3$  stories in height
  - Gravity (nonmotorized) allowed

# Mandatory Requirements – Loading Dock Weatherseals (502.4.6)



- Equip cargo doors and loading dock doors with weatherseals
- Goal is to restrict infiltration

# Mandatory Requirements – Vestibules (502.4.7)

- Required to reduce infiltration into spaces
- Required on entrance doors leading into spaces  $\geq 3,000$  ft<sup>2</sup>
- Doors must have self-closing devices
- Exceptions
  - Buildings in Climate Zones 1 and 2
  - Doors from a guest room or dwelling unit
  - Doors used primarily for vehicular movement, material handling and adjacent personnel doors

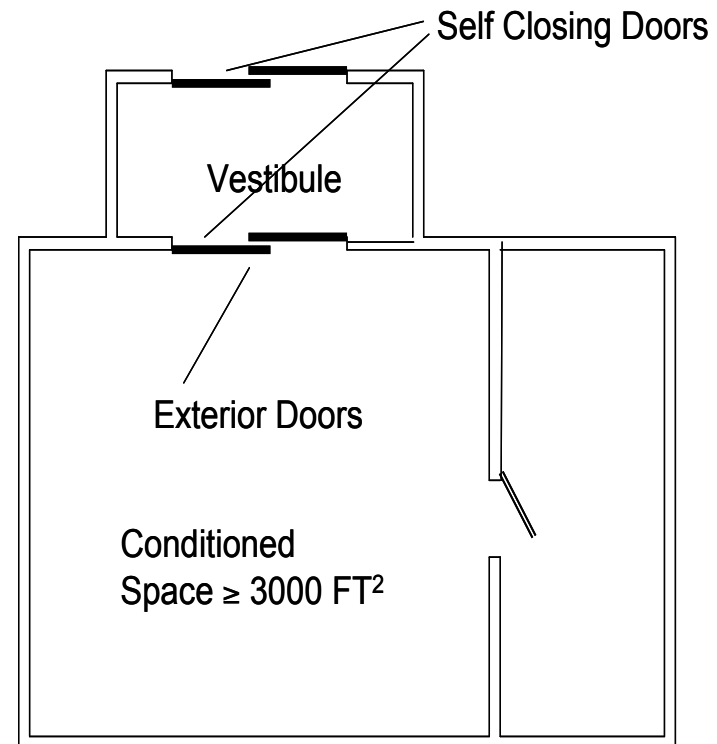

# Mandatory Requirements – Recessed Lighting (502.4.8)

All recessed luminaires installed in the building envelope

- Type IC rated and sealed with gasket or caulk between housing and interior wall or ceiling covering
- Type IC rated and labeled in accordance with ASTM E 283 to allow  $\leq 2.0$  cfm of air movement from conditioned space to ceiling cavity

